



## Fifth Wheel King Pin User Guide

**EXECUTIVE**

TORSION  FLEX





# Torsion Hitch USERS GUIDE

This product is protected by Patent # US9505281B1, USD773345S1, USD9868327B1



SCAN ME!

To install, simply use the same amount of bolts you removed to replace the pin box.

Minimum of 4 mounting bolts per side are required.

Torque mounting bolts to: 160 ft. lbs.

Use  $\frac{5}{8}$ " x  $1 \frac{1}{2}$ " grade 8 bolts & nuts

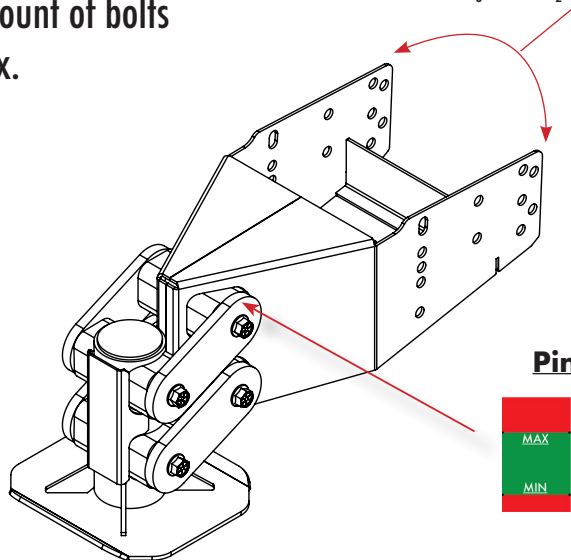

## Pin Weight Scale



**AVERAGE BREAK-IN PERIOD: 1,000 MILES**

\* GEN-Y Hitch shall NOT be held responsible for any or all "compatible parts or products" being used or being utilized for towing with or around GEN-Y Hitch.

\* GEN-Y Hitch products shall never be altered in any circumstances or for any reason and will void any warranties if done so.